



Model C6-200  
**SMALL  
ANIMAL  
CREMATORY**



*The next generation...  
from a leading maker of Animal Crematories*

**Shenandoah**

**All the features you've been looking for!**

- Single batch load capacity up to 200 lbs. of carcasses
- Easy loading 33 in. height for heavy animals
- No visible stack emissions or odors; EPA compliance
- Save fuel... Temperature Controller cycles primary burner on/off
- Easy to use... Set timers and walk away
- Thick high temperature refractory lining throughout... Extends equipment life
- Available with either Natural Gas or LPG burners

**LOWEST EQUIPMENT OPERATING  
COST IN THE INDUSTRY!**

*Designed specifically for...*

**Veterinarians  
Humane Societies  
Small Animal Control**

Distributed By:

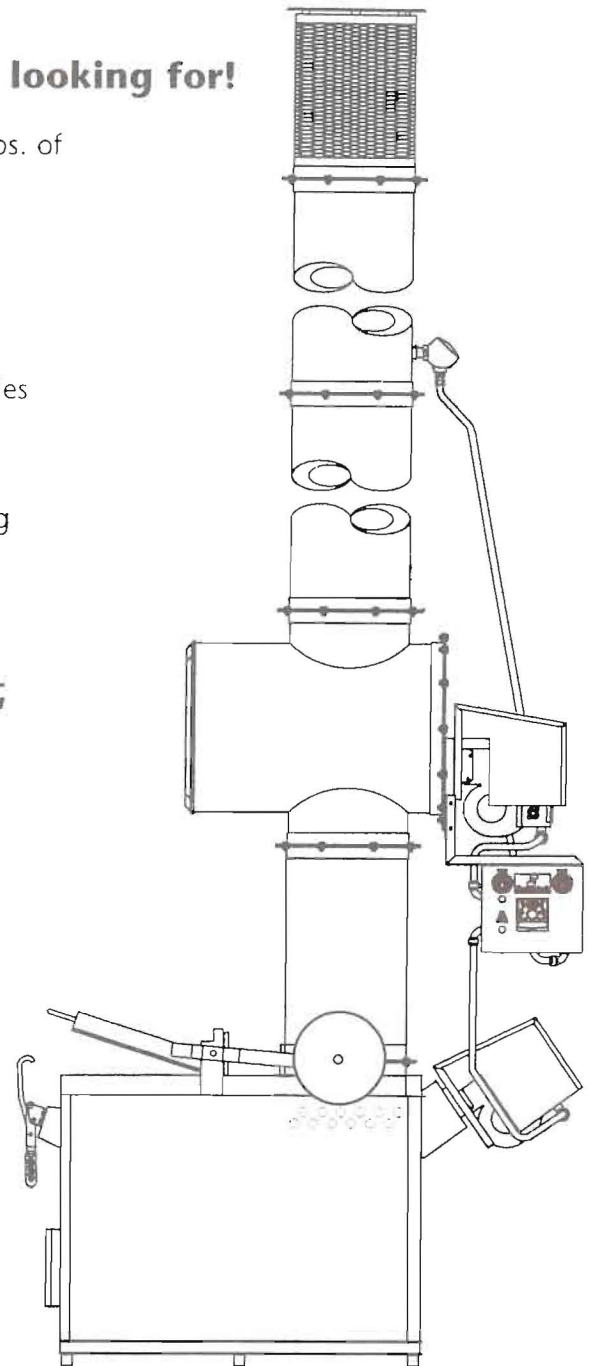

Model C6-200

Firelake Mfg. LLC  
919 Cottontail Trail, Mt. Crawford, VA 22841

Phone: 866-252-3757  
Fax: 866-252-3877  
[www.firelakemfg.com](http://www.firelakemfg.com)

# Benefits and Features of Shenandoah's C-6

## Fast, complete, efficient waste disposal

- Concave refractory bottom specifically designed to insure burnout and total destruction of liquid wastes.
- Secondary chamber and insulated, refractory-lined stacks for emissions control.

## Minimum installation and start-up time

- Factory assembled, aluminized steel jacket lined with high-temperature refractory.
- Recorders and other accessory equipment available.

## Easy and safe operation

- Counter-balanced fill door.
- Timer control system for each burner provides preset burn times and automatic shut off.

## Low energy consumption levels

- Temperature control maintains temperature, assuring complete combustion while conserving fuel.
- Choice of fuels: LP or natural gas.

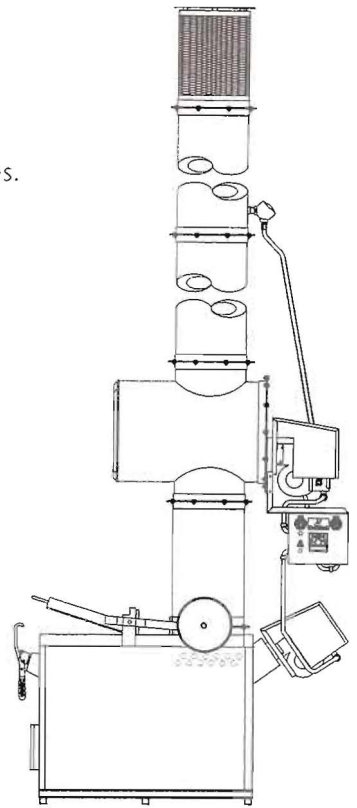

## Specifications Summary

**C6-2GLP-T** Propane-Fired Cremation System complete with two burners, secondary chamber, stack, timers, and temperature control

**C6-2GN-T** Natural Gas-Fired Cremation System complete with two burners, secondary chamber, stack, timers, and temperature control

WASTE CHAMBER			<b>Installation</b> Must be installed in accordance with local codes and ordinances, subject to regulatory agencies. Outside installation is recommended with a simple metal roof or three-sided metal shelter, providing a <i>minimum</i> of four foot clearance from any combustible material. Minimum of 18" clearance is required for penetration of combustible roof materials. Inside installations may have special insurance requirements. Factory must be advised.  <b>GENERAL</b> Electrical service Standard—115 volt, 60 HZ, 20 amp Also available—220 volt, 50 HZ, 10 amp  <b>BURNERS</b> • LP or natural gas burner with spark ignition and flame safety shut-off Operation 2 manual timers  <b>TOTAL WEIGHT:</b> 2432 lbs. (appr.) 1107 kg
Chamber capacity (Type IV waste—pathological)			
	200 lbs	91 kg	
Chamber volume			
	6.3 feet <sup>3</sup>	.18 m <sup>3</sup>	
Chamber size (outside)			
Width	26"	66 cm	
Height	33"	84 cm	
Length	42"	107 cm	
Door opening			
	14" x 20"	36 x 51 cm	
Height to door			
	33"	84 cm	
Height to top of chamber			
	33"	84 cm	
Height to top of secondary chamber			
	7'6"	2.3	
Overall dimensions (w/stack)			
	18'H x 34"W x 60"L	(5.5m x 86cm x 152cm)	
Suggested slab size (l x w x thick)			
	10' x 12' x 6"	3 m x 3.7 m x 10 cm	
<b>STACK</b>			
Dimensions			
	14" outside dia.	36 cm OD	
Material			
	14 gauge Aluminized Steel jacket, refractory lined		
<b>REFRACTORY THICKNESS</b>			
Primary	3.0" (2800° F)	7.6 cm	
Secondary	1.5" (2800° F)	3.8 cm	
Stack	1.5" (2800° F)	3.8 cm	
	<b>C6-2GLP-T</b>	<b>C6-2GN-T</b>	
<b>APP. FUEL CONSUMPTION</b>	<b>LP</b>	<b>NATURAL GAS</b>	
Upper Burner	4.1 GPH	392 CFH	
Lower Burner	3.0 GPH	275 CFH	
	(1.5 GPH*)	(138 CFH*)	
<b>APPROXIMATE BTU'S</b>			
Upper Burner	414,000	415,000	
Lower Burner	275,000	275,000	

\*Approximate reduced fuel consumption of lower burner is a result of burner cycling on & off.

\*Fuel consumption approximate. Actual fuel use depends on BTU content of waste. Consult factory for longer retention times or special requirements.



Firelake Mfg. LLC  
 919 Cottontail Trail, Mt. Crawford, VA 22841

Phone: 866-252-3757  
 Fax: 866-252-3877  
 www.firelakemfg.com