



# P9 Series ANIMAL CREMATORY SYSTEMS

# Shenandoah

## Discover the advantages of

- high-profit cremation
- low-cost disposal

## Designed for

- veterinary practices
- animal-control facilities
- pet cemeteries
- destruction of Type IV pathological waste

*Since 1962 the Shenandoah brand has defined high quality incineration/cremation equipment designed for economical ease of use. This cremation system is:*

### Environmentally safe

Waste can be destroyed as fast as it accumulates. High temperatures convert pathological or contaminated waste into sterile ash without offensive smoke or odor.

### Convenient

Simply load the incinerator and start the burners by setting the timers. No watching is required since the timers automatically shut the burners off.

### Thorough

Leaves only fine or brittle white ashes. Reduces 200 pounds of Type IV pathological waste to approximately 10 pounds of sterile residue.

### Installation:

The P9 must be installed in accordance with local codes and ordinances, subject to regulatory agencies. Stack test data is available from the distributor for permit application. If on-site testing is required, it is the responsibility of the purchaser and can be arranged through the distributor. Outside installation is recommended with a simple metal roof or three-sided metal shelter. Inside installations may have special insurance requirements.

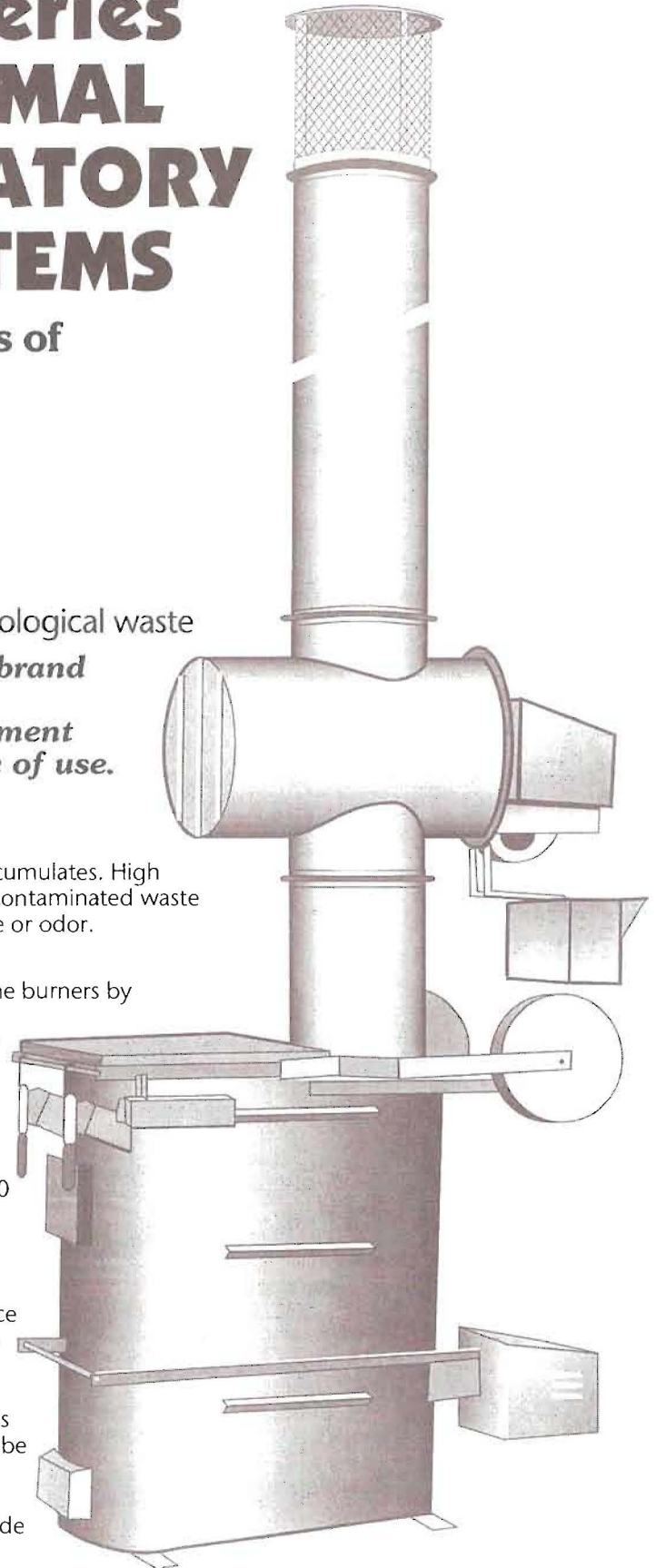

Firelake Mfg. LLC  
919 Cottontail Trail, Mt. Crawford, VA 22841

Phone: 866-252-3757  
Fax: 866-252-3877  
[www.firelakemfg.com](http://www.firelakemfg.com)

# Benefits and Features of Shenandoah's P-9

## Fast, complete, efficient waste disposal

- Heavy duty ceramic grates allow burning from below.
- Concave refractory bottom acts as a hearth for waste that falls through grate openings.
- Secondary chamber with baffle and insulated connector stacks.

## Minimum installation and start-up time

- Factory assembled, aluminized steel jacket lined with high-temperature refractory and firebrick.
- Recorders and other accessory equipment available.

## Easy and safe operation

- Large counter-balanced fill door with electrical lockout.
- Automatic timer control system for each burner provides preset burn times and automatic shut off.

## Low energy consumption levels

- Digital temperature controls maintain temperature, assuring complete combustion while conserving fuel.
- Choice of fuels: #1 or #2 fuel oil, LP or natural gas.

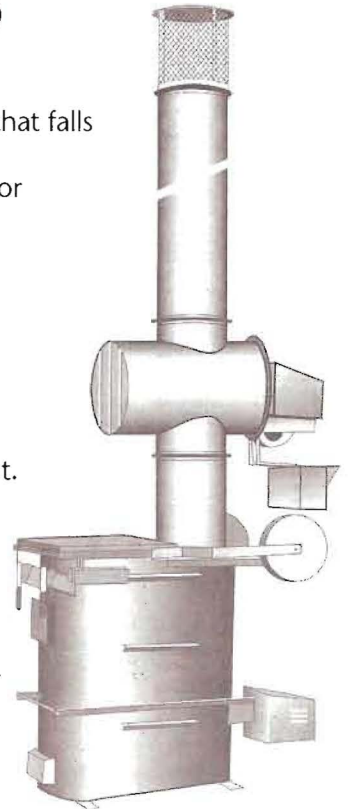

## Specifications

- P9-2GLP-T** Propane-Fired Cremation Systems complete with two burners, secondary chamber, stack, timers and temperature control  
**P9-2GN-T** Natural Gas-Fired Cremation Systems complete with two burners, secondary chamber, stack, timers and temperature control  
**P9-20-T** Oil-Fired Cremation Systems complete with two burners, secondary chamber, stack, timers and temperature control

Chamber capacity	9 cu. ft., 200 lbs., Type IV Waste	
Chamber dimensions	27½" high, 19" wide, 34½" long	
Fill door opening	18½" by 19"	
Height to top of secondary chamber	8'6"	
Overall dimensions with stack	5' x 3½' x 20'	
Electrical	115V 60 Hz. <i>Optional, 220V 50Hz</i>	
Weight	2400 lbs.	
Suggested slab size	without shelter	5' wide, 6' long, 6" thick
	with shelter	10' wide, 12' long, 6" thick

### Charging rate

**Pathological**  
 Up to 400 pounds per ten-hour day of Type IV, pathological waste rated at 1000 BTU's per pound. *Based on batch loading twice daily. Dependent upon reloading regulations. Additional time may be required for burnout of final charge.*

	P9-2GLP-T	P9-2GN-T	P9-20-T
<b>FUEL CONSUMPTION</b>	<b>LP</b>	<b>Natural</b>	<b>Oil</b>
Upper burner	4.08 GPH	392 CFH	2.5 GPH
Lower burner	1.83 GPH (1.09 GPH*)	205 CFH (98 CFH*)	1.0 GPH (.5 GPH*)
<b>APPROXIMATE BTU</b>			
Upper burner	375,000	392,000	325,000
Lower burner	200,000	205,800	130,000

\*Approximate reduced fuel consumption of lower burner is a result of burner cycling on & off.



**Firelake Mfg. LLC**  
 919 Cottontail Trail, Mt. Crawford, VA 22841

Phone: 866-252-3757  
 Fax: 866-252-3877  
[www.firelakemfg.com](http://www.firelakemfg.com)